

Universal Inspection and Measuring Technology
for Process-Oriented Tool Inspection

ZOLLER
expect great measures

smartCheck



We Stand for Smart Progress

ECONOMICS

Are you looking for a powerful universal inspection and measuring device for your cutting tools? ZOLLER offers its customers various solutions for checking tools in the most economical way before and after sharpening – unbeatable, indispensable and 100% convincing.

Experience great measuring performance at a good price. With the ZOLLER »smartCheck«, you can inspect and measure your tools and grinding wheels right next to the machine. Even when inspecting your tools before the resharpening process, you can achieve a high-precision quality check. This way, you avoid unnecessary stock removal during resharpening and produce economically. Whether as a manual basic version or as a CNC version for fully automatic measuring processes, ZOLLER always offers top performance for your tool inspection – make your choice and see the benefits!

Compact measuring technology

Universal quality control

Certified safety



Tool Quality – Process-Oriented and Precise

The ZOLLER »smileCheck« is impressive not only because of its convenient operating concept, but because of its compact design. That is how it ensures reliable processes and more speed in your production. Tool parameters, geometry data and cutting contours can be recorded both radially and axially. The »smileCheck« also enables you to prepare your grinding wheel packs quickly and precisely.



»smileCheck«

Calibrating measuring machines on site with certified inspection tools and reference standards is an important part of quality assurance at E. ZOLLER GmbH & Co. KG. This enables us to guarantee reliable measurement results and the high precision of your products in accordance with applicable standards.



Accredited calibration laboratory
according to DIN EN ISO/IEC 17025:2018

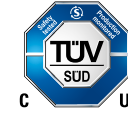

Quality Management/Environmental Management
according to ISO 9001, VDA 6.4 and ISO 14001

ZOLLER

The »smartCheck 450/600/800« series from ZOLLER offers you comprehensive tool inspection. State-of-the-art technology paired with outstanding ease of use ensure efficient process sequences in your production. The wide variance of measuring ranges and the variable equipment make the »smartCheck« the perfect solution for your demanding range of tools. You can rely on precise measurement data that guarantees the quality of your products.



»smartCheck 450/600/800«

We Stand for Unmatched Precision

TECHNOLOGY

A »smartCheck« from ZOLLER is easy to handle and impresses across the board. The basic version is already equipped with a wide range of features and can be flexibly expanded at any time with software packages.

Every ZOLLER machine is a promise to our customers. ZOLLER presetting, measuring and inspection machines are ideal for day-to-day use in any production environment and have truly earned their rightful place next to the CNC machine. The transmitted and incident light optics support your measuring processes right through to checking in the resharpening process, so you always ensure the precise quality of your tools throughout the entire production process.

The careful assembly of high-quality brand components ensures a long service life for your ZOLLER machine. At ZOLLER, we do everything we can to ensure unbeatable high-precision over the long term.

STEFAN KAHN

Part of the ZOLLER assembly team

Production at premium level

Functional design

Maximum operating comfort



Compact Base Model

»smileCheck« TÜV and UL/CSA Approved

Every »smileCheck« is certified according to international standard IEC/EN 61010-1 and cNRTLus.

Proven and certified safety.

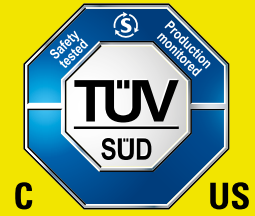

Ergonomic one-hand control handle »eQ« (ergonomic & quick) – to easily move the optics carrier to the correct position in the Z- and X-axes. The button with the Solutions symbol can be individually configured with additional practical functions, making operation even easier and more convenient.

Z-, X-axis manual/CNC – the high-precision and smooth-running linear axes are used for fast and fine positioning of the measuring optics to the tool cutting edge. Whether manually for spot checks using the »eQ« one-hand control handle or CNC-controlled for fully automatic processes, these allow the measurement to be carried out safely, quickly and conveniently.

Manual fine adjustment – the alternative to CNC control. The ergonomic handwheels for additional manual fine adjustment of the Z- and X-axes are particularly suitable for the tool inspection module.



Y-axis – the optional, CNC-controlled linear axis for measuring off-center cutting edges on turning or multifunctional tools.



Practical storage board – holds adapter tool posts, adapters, tools and intermediate sleeves.

Tool inspection with manually swiveling incident light camera – for radial and axial inspection and measurement tasks. The integrated LED ring light with adjustable light intensity ensures optimum illumination of the surface. The clamping and locking device as well as the swivel range of -30° to 90° ensure an ideal perspective for the respective measuring point.



Software »pilot 4.0« – is self-explanatory, clearly laid out and enables the operator to take reliable measurements. It offers a uniform user interface on all ZOLLER systems – right up to ZOLLER TMS Tool Management Solutions. The individual structure of the software allows customer-specific adaptations to be implemented quickly.

Integrated control unit – offers an ergonomic and comfortable work area. The 24" TFT color monitor can be individually adapted to the needs of each operator. The height, swivel and tilt angle can be flexibly adjusted.

High-precision spindle SK 50 – for holding tools or adapters with interface SK 50. Adapters for reduction allow simple and precise clamping of almost any tool holding system. The optional CNC drive with autofocus and precise angle measuring system offers automatic focusing of the tool cutting edge and recording of the die contour.

Label printer – for printing the measurement results or DataMatrix codes on adhesive paper or thermal labels.

Stable table – forms the base of the device. Electronics and pneumatic elements are stored here in an industrial and service-friendly manner, all neatly laid out with sufficient space for good accessibility and optimum ventilation.

Inspection at Premium Level

»smartCheck 450« TÜV and UL/CSA Approved

Every »smartCheck 450« is certified according to international standard IEC/EN 61010-1 and cNRTLus.

Proven and certified safety.

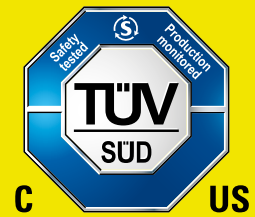

Ergonomic one-hand control handle »eQ« (ergonomic & quick) – to easily move the optics carrier to the correct position in the Z- and X-axes. The button with the Solutions symbol can be individually configured with additional practical functions, making operation even easier and more convenient.

Z-, X-axis manual/CNC – the high-precision and smooth-running linear axes are used for fast and fine positioning of the measuring optics to the tool cutting edge. Whether manually for spot checks using the »eQ« one-hand control handle or CNC-controlled for fully automatic processes, these allow the measurement to be carried out safely, quickly and conveniently.

Manual fine adjustment – the alternative to CNC control. The ergonomic handwheels for additional manual fine adjustment of the Z- and X-axes are particularly suitable for the tool inspection module.



Y-axis – the optional, CNC-controlled linear axis for measuring off-center cutting edges on turning or multifunctional tools.



Practical storage board – holds adapter tool posts, adapters, tools and intermediate sleeves.

Stable table – forms the base of the device. Electronics and pneumatic elements are stored here in an industrial and service-friendly manner, all neatly laid out with sufficient space for good accessibility and optimum ventilation.

Tool inspection with manually swiveling incident light camera – for radial and axial inspection and measuring tasks. The integrated LED ring light with adjustable light intensity ensures optimum illumination of the surface. The clamping and locking device as well as the swivel range of -30° to 90° ensure an ideal perspective for the respective measuring point.



Software »pilot 4.0« – is self-explanatory, clearly laid out and enables the operator to take reliable measurements. It offers a uniform user interface on all ZOLLER systems – right up to ZOLLER TMS Tool Management Solutions. The individual structure of the software allows customer-specific adaptations to be implemented quickly.

Separate control unit »cockpit« – offers space for keyboard and mouse as well as shelves for label and laser printers, scanners and tools. The height and angle of the 24" TFT color monitor can be adjusted to make using the software as comfortable as possible. This means that every operator can set up the workstation individually in just a few simple steps.

High-precision spindle »ace« – guarantees µm-accurate clamping of tools and holders of all kinds. Adaptation to many tool holder systems is guaranteed by the universal adapter tool post changing system. The optional CNC drive with autofocus and precise angle measuring system offers automatic focusing of the tool cutting edge and recording of the cutting contour.



Top Model for the Highest Demands

»smartCheck 600/800« TÜV and UL/CSA Approved

Every »smartCheck 600/800« is certified according to international standard IEC/EN 61010-1 and cNRTLus.

Proven and certified safety.

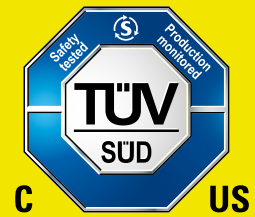

Ergonomic one-hand control handle »eQ« (ergonomic S quick) – to easily move the optics carrier to the correct position in the Z- and X-axes. The button with the Solutions symbol can be individually configured with additional practical functions, making operation even easier and more convenient.

Z-, X-axis manual/CNC – the high-precision and smooth-running linear axes are used for fast and fine positioning of the measuring optics to the tool cutting edge. Whether manually for spot checks using the »eQ« one-hand control handle or CNC-controlled for fully automatic processes, these allow the measurement to be carried out safely, quickly and conveniently.

Manual fine adjustment – the alternative to CNC control. The ergonomic handwheels for additional manual fine adjustment of the Z- and X-axes are particularly suitable for the tool inspection module.



Y-axis – the optional, CNC-controlled linear axis for measuring off-center cutting edges on turning or multifunctional tools.



Practical storage board – holds adapter tool posts, adapters, tools and intermediate sleeves.

Stable table – forms the base of the device. This is where the computer, electronics and pneumatic elements are stored in an industrial and service-friendly manner, all neatly laid out with sufficient space for good accessibility and optimum ventilation.

Swiveling optics carrier – the optional CNC-controlled swiveling device of the transmitted light optics with a swivel range of -30° to 30° for distortion-free measurement of tool contours with a slope.

Tool inspection with manually swiveling incident light camera – for radial and axial inspection and measuring tasks. Integrated multi-LED ring light segmented into eight areas with adjustable light intensity ensures optimum illumination of the surface. The clamping and locking device as well as the swivel range of -30° to 90° ensure an ideal perspective for the respective measuring point.



Software »pilot 4.0« – is self-explanatory, clearly laid out and enables the operator to take reliable measurements. It offers a uniform user interface on all ZOLLER systems – right up to ZOLLER TMS Tool Management Solutions. The individual structure of the software allows customer-specific adaptations to be implemented quickly.

Separate control unit »cockpit« – offers space for keyboard and mouse as well as shelves for label and laser printers, scanners and tools. The height and angle of the 24" TFT color monitor can be adjusted to make using the software as comfortable as possible. This means that every operator can set up the workstation individually in just a few simple steps.

High-precision spindle »ace« – guarantees μm -accurate clamping of tools and holders of all kinds. Adaptation to many tool holder systems is guaranteed by the universal adapter tool post changing system. The optional CNC drive with autofocus and precise angle measuring system offers automatic focusing of the tool cutting edge and recording of the cutting contour.



High-Precision Optics for Tool Inspection

The ZOLLER »smileCheck« and »smartCheck« series are your solutions for high-quality, industry-standard optics. Cutting edge radii, angles, lengths, diameters, etc. can be measured automatically and with μm -accuracy on the outer contour of the tools using transmitted light. Stored measurement sequences are carried out fully automatically at the touch of a button (CNC version). In incident light, manual measurements can be carried out in the chip space, on the circumference and on the face. The cutting edge detection supports operator-independent measurements. Your incident light measurements are automated using innovative software packages. The high-resolution cutting edge images are also ideal for your documentation.

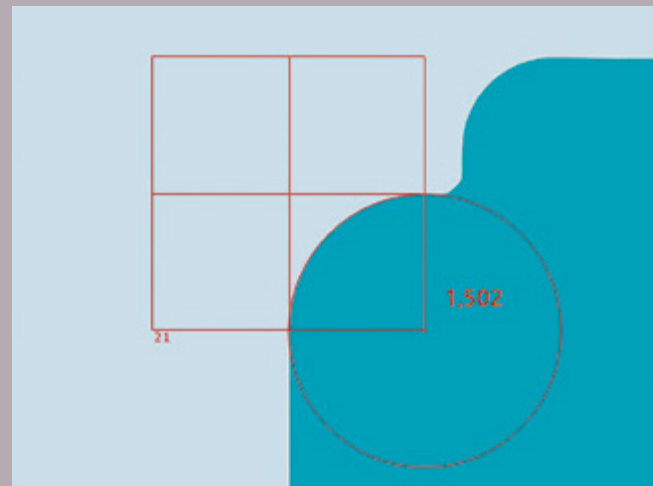

Transmitted light measurement on the circumference

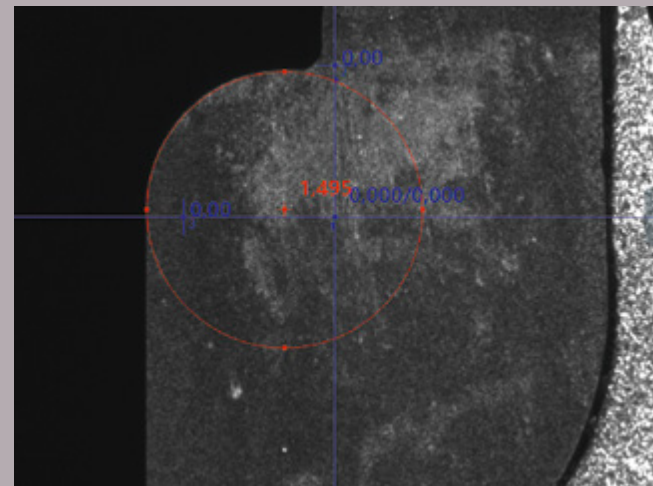

Contour measurement in the chip space

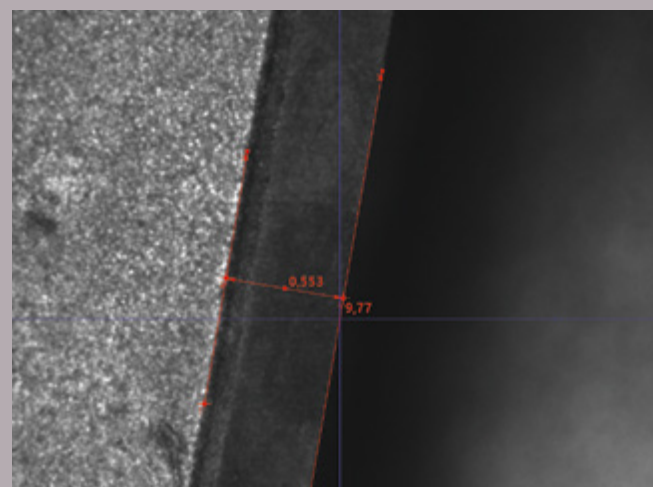

Incident light measurement on the circumference

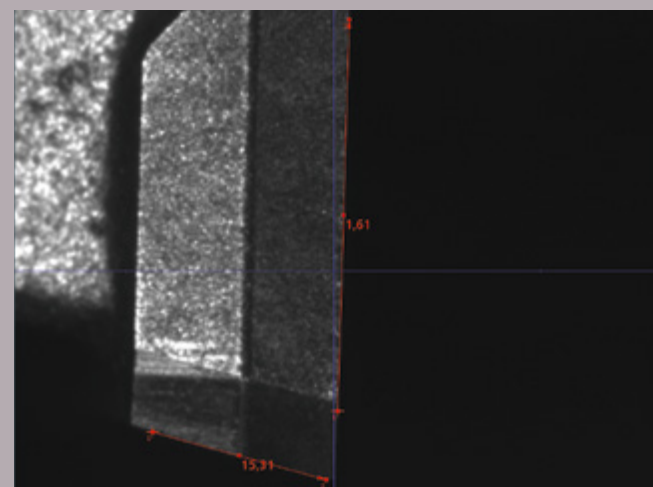

Incident light measurement on the face

Sensors configuration	»smileCheck«	»smartCheck 450«	»smartCheck 600«
Optics transmitted light			
Transmitted light camera HR50, BF approx. 7.3 x 6.7 mm ²	●	●	●
Transmitted light camera HR50 1:1, BF approx. 4.0 x 3.6 mm ²	–	⊙	⊙
Transmitted light camera HR70 1:1, BF approx. 4.0 x 3.6 mm ²	⊙	⊙	⊙
Transmitted light camera 5 Mpx, BF approx. 4.4 x 4.0 mm ²	–	⊙	⊙
Transmitted light camera WF, BF approx. 15.5 x 14.1 mm ²	–	–	⊙
Optics incident light for tool inspection			
Incident light camera, BF approx. 7.1 x 6.5 mm ²	●	●	–
Incident light camera, BF approx. 4.4 x 4.0 mm ²	–	–	●
Tool inspection			
Indexable 0° and 90°, infinitely variable clamping	●	●	●
Swivel range -30° to 90°	●	●	●
Multi-LED incident light 8-fold segmentable	–	–	●

● Base model ⊙ optional – not possible

Spindle Technology for your »smileCheck«

Advantages of the ZOLLER high-precision spindles

- Clamp everything. Measure everything. Accelerate everything.
- Fast, µm-accurate changeover
- Universal for all tool holders

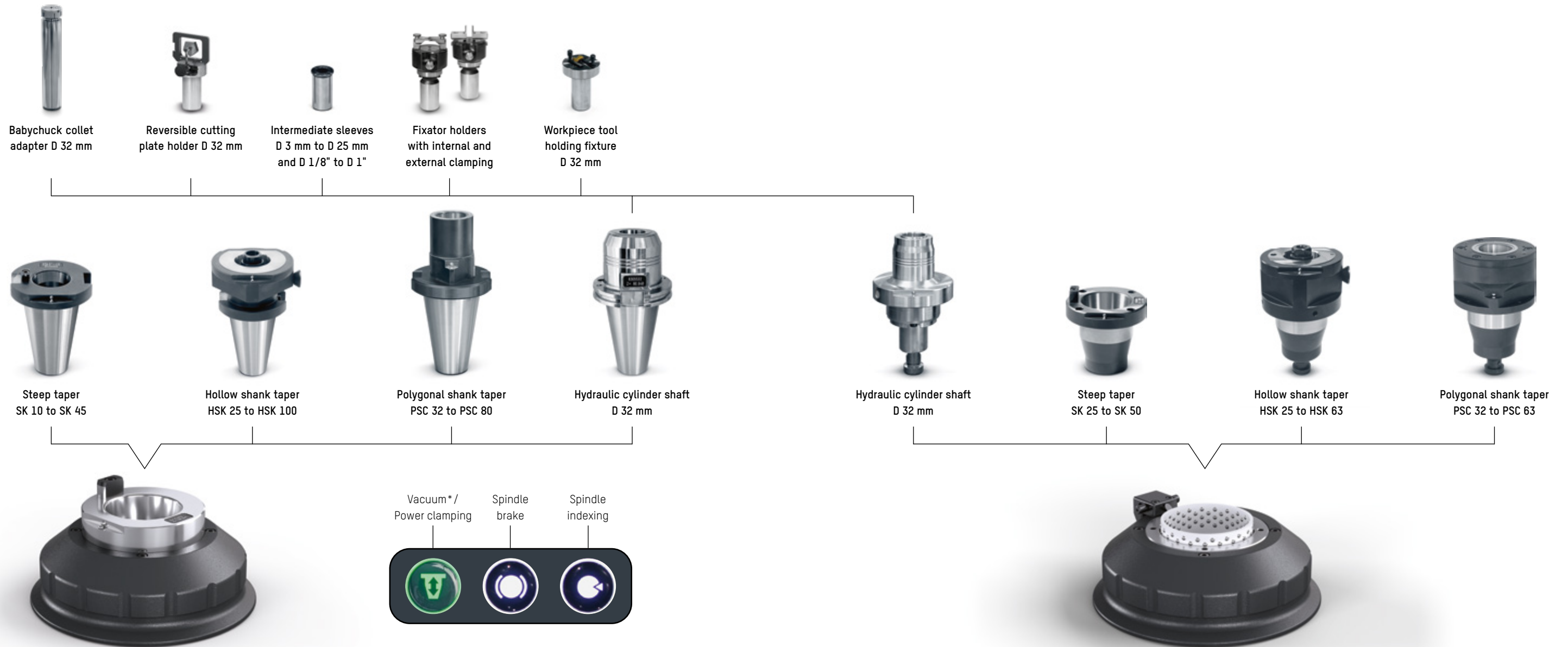

High-precision spindle SK 50 – with optional vacuum clamping

- High axial and radial run-out accuracy – better than 2 µm
- Ergonomic spindle handwheel – for safe rotation of the spindle and precise focusing of the tool cutting edge
- Pneumatic spindle brake and indexing – for fixing the spindle in the desired position
- Quick adapter change – in a maximum of 10 seconds
- Integrated calibration spheres on the spindle and adapters – for simple, quick and precise determination of the spindle zero point

High-precision spindle »pcs« – with power clamping and quick-change system

- Power-operated tool clamping – constant, independent of the user
- High axial and radial run-out accuracy – better than 2 µm
- Ergonomic spindle handwheel – for safe rotation of the spindle and precise focusing of the tool cutting edge
- Pneumatic spindle brake and indexing – for fixing the spindle in the desired position
- High changing accuracy of adapter tool posts – better than 1 µm
- Quick adapter tool post change – in less than 10 seconds
- Integrated calibration spheres on adapter tool posts – for simple, fast and precise determination of the spindle zero point

*optional

Spindle Technology for your »smartCheck«

Advantages of the ZOLLER high-precision spindles

- Clamp everything. Measure everything. Accelerate everything.
- Fast, µm-accurate changeover
- Universal for all tool holders



Hollow shank taper
HSK 25 to HSK 125



Steep taper
SK 25 to SK 60



Polygonal shank taper
PSC 32 to PSC 100



Hydraulic cylinder shaft
D 32 mm

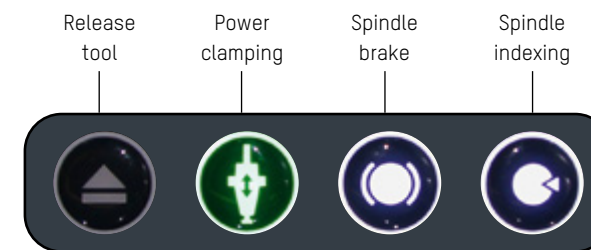
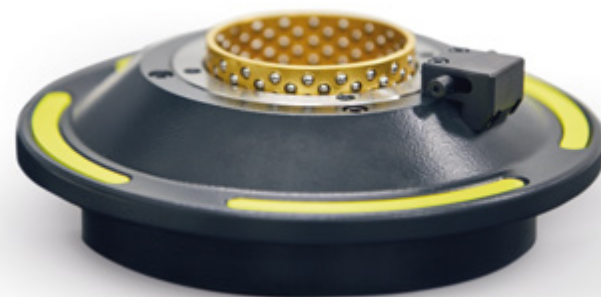

High-precision spindle »ace« – with power clamping and quick-change system

Power-operated tool clamping – constant, independent of the user

High axial and radial run-out accuracy – better than 2 µm

Ergonomic spindle handwheel – for safe rotation of the spindle and precise focusing of the tool cutting edge

Pneumatic spindle brake and indexing – for fixing the spindle in the desired position

High changing accuracy of adapter tool posts – better than 1 µm

Quick adapter tool post change – in less than 10 seconds

Integrated calibration spheres on adapter tool posts – for simple, quick and precise determination of the spindle zero point

Automatic zero point selection – automatic detection and calibration of the adapter tool post used

Intuitive and Intelligent – Software »pilot 4.0«

ZOLLER's »pilot 4.0« has established itself as a powerful and comprehensive software solution for all ZOLLER presetting, measuring and inspection machines. The intuitive, graphical interface guides the user quickly and reliably to precise measurement results. Thanks to »pilot 4.0«, even complex measuring tasks can be completed at the first attempt. At the same time, the software is so comprehensive in its functionality that there is a solution for every requirement. It stands to reason that »pilot 4.0« is the world's unrivaled benchmark for measuring, inspecting and managing cutting tools.



Software »pilot 4.0« – with graphical user interface for intuitive operation. Stored measurement sequences guarantee automatic and operator-independent inspection and measurement. In addition, automatic cutting edge shape recognition is available for random samples without the need to create data.



Software packages »inspection« – »Basic«, »Advanced«, »Premium« flexibly extend the range of functions of the basic version according to the respective measurement requirements. The data creation of the measuring programs is unsurpassed in its simplicity. The photo-realistic input dialog »fored« guides you safely through the parameter input.

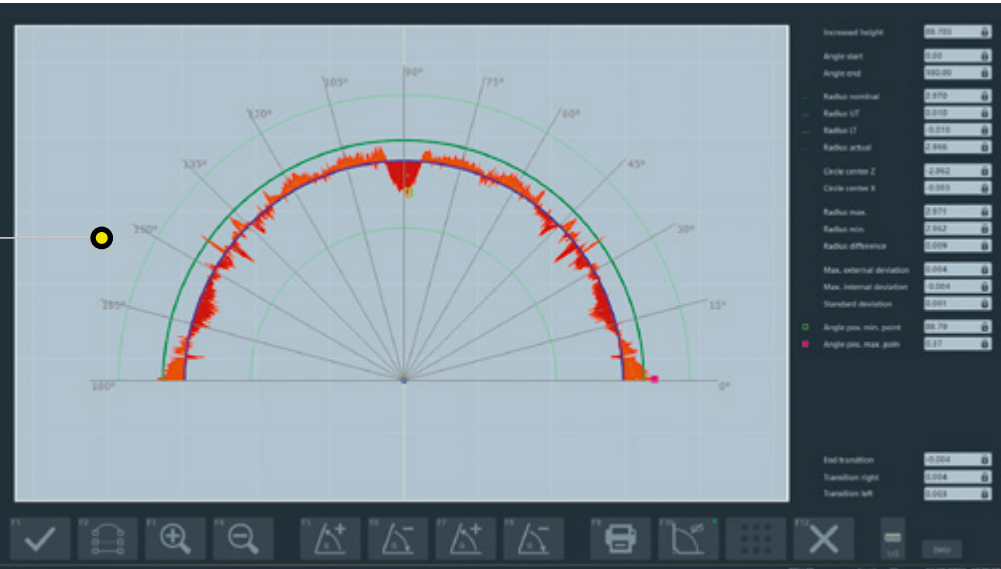

Radius contour »contur« with graphics – for automatic determination of concave and convex radii on the outer contour of tools including adjustable angle sectors with graphical evaluation.

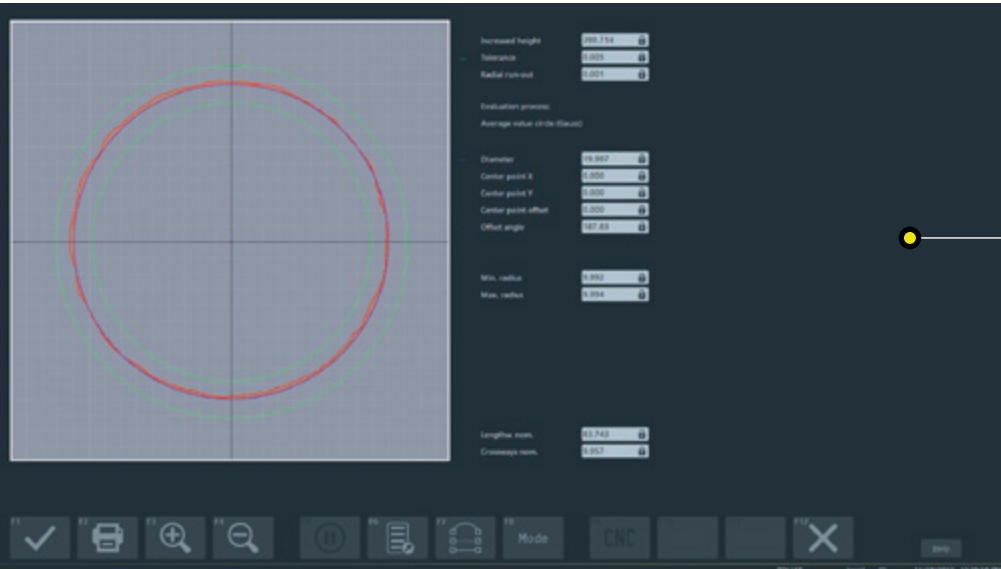

Concentricity check 360° – to automatically determine the radial run-out on circular surfaces (e.g. tool shank) and graphically evaluate the entire contour. This functionality is also the basis for automatic concentricity and wobble compensation.

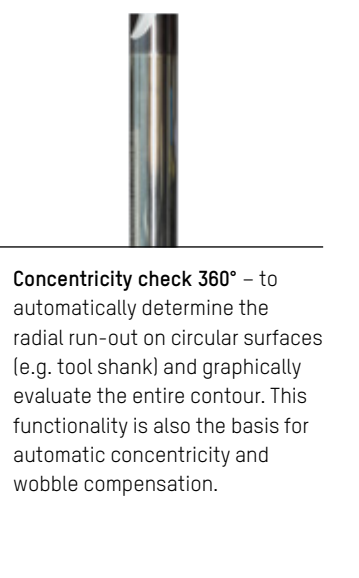
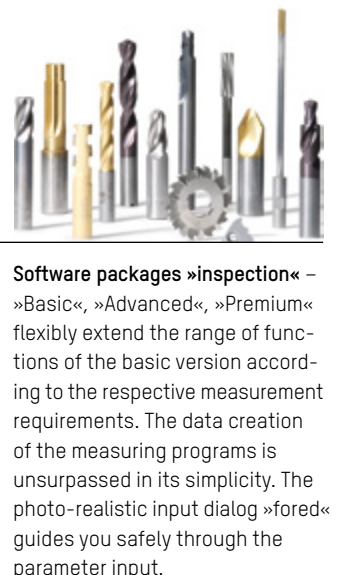

Tool Analysis Made Easy

Equipped with a swiveling incident light camera, the ZOLLER »smileCheck« and »smartCheck« series are excellent for tool inspection. Tool parameters, geometry data and cutting edge contours are recorded both radially and axially, making tool analysis universal, quick and easy.

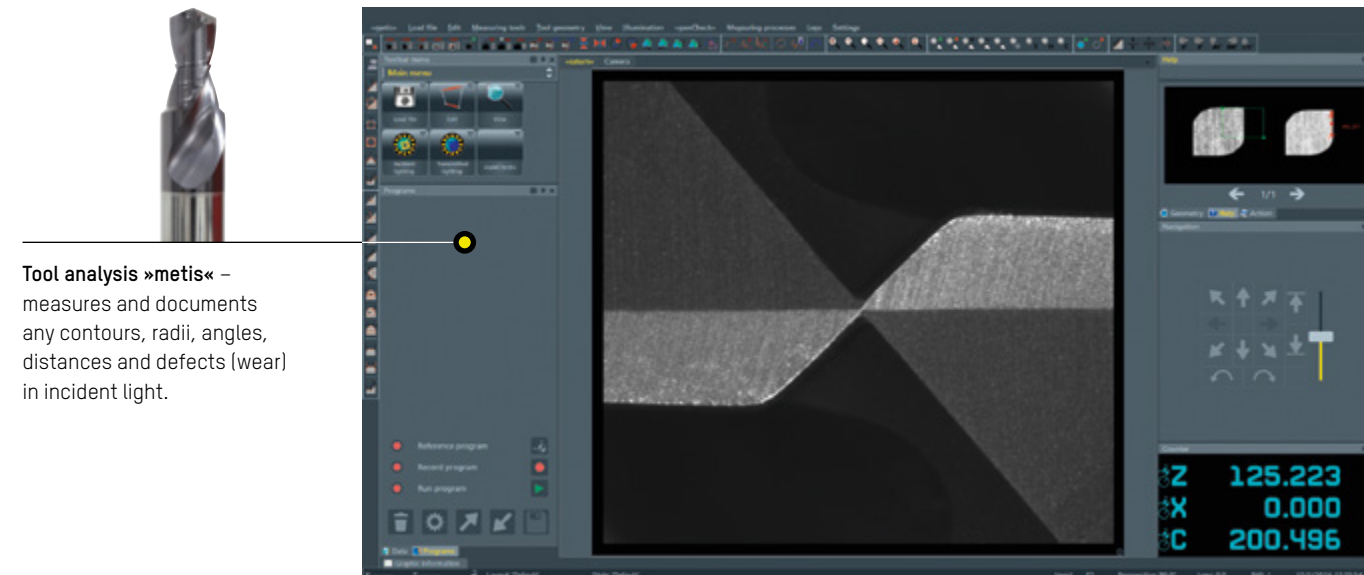

Tool analysis »metis« – measures and documents any contours, radii, angles, distances and defects (wear) in incident light.

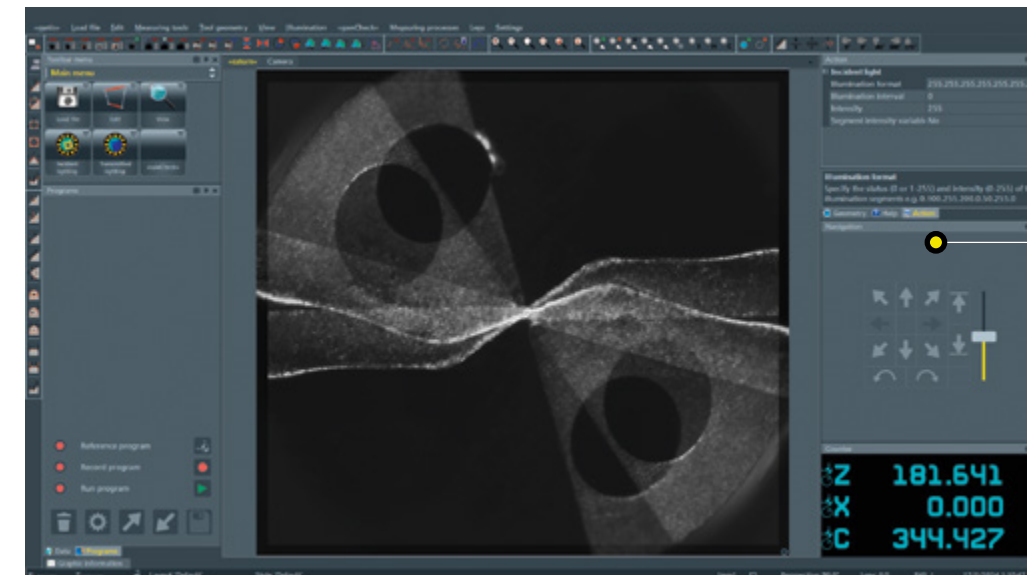

Tool analysis »metis« – The display of a transparent reference image saved by the master tool at the touch of a button enables a quick visual comparison of the tool to be inspected with its nominal geometry.

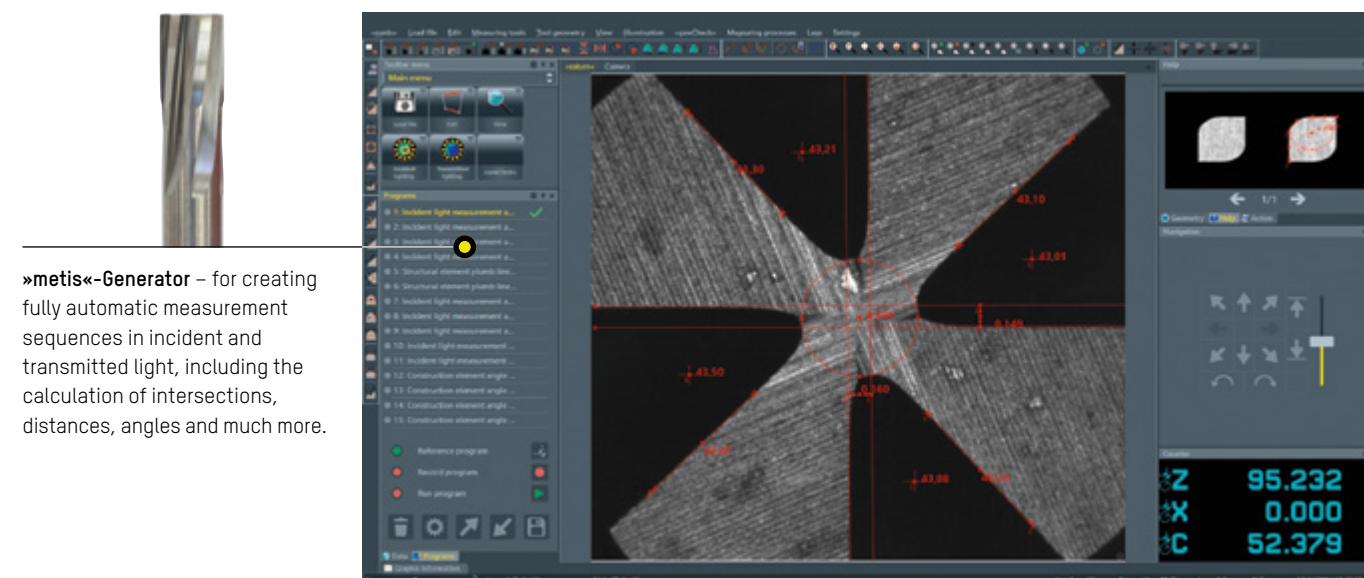

»metis«-Generator – for creating fully automatic measurement sequences in incident and transmitted light, including the calculation of intersections, distances, angles and much more.



DXF contour projection »telesto« – display of a DXF file in incident and transmitted light as nominal contour for quick and easy comparison to the tool contour.

Check Tool Contours in Detail

The ZOLLER software developed with and for tool manufacturers offers you solutions for the highest demands. Even complex measuring and inspection tasks are ingeniously simple to use.



Contour measurement »lasso« – for scanning any tool or work-piece contours and creating a nominal/actual comparison based on a DXF nominal contour with a variable tolerance range.

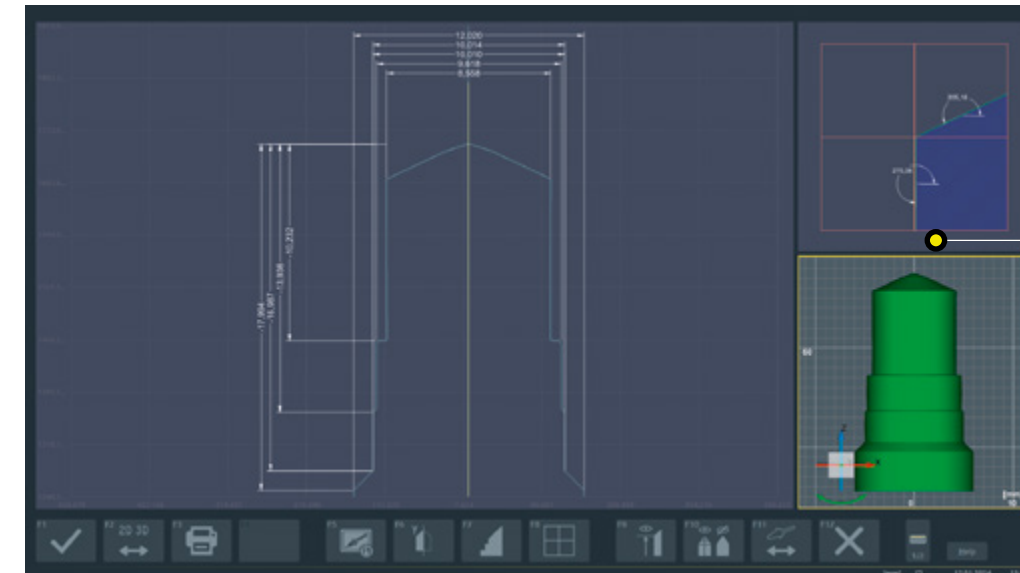
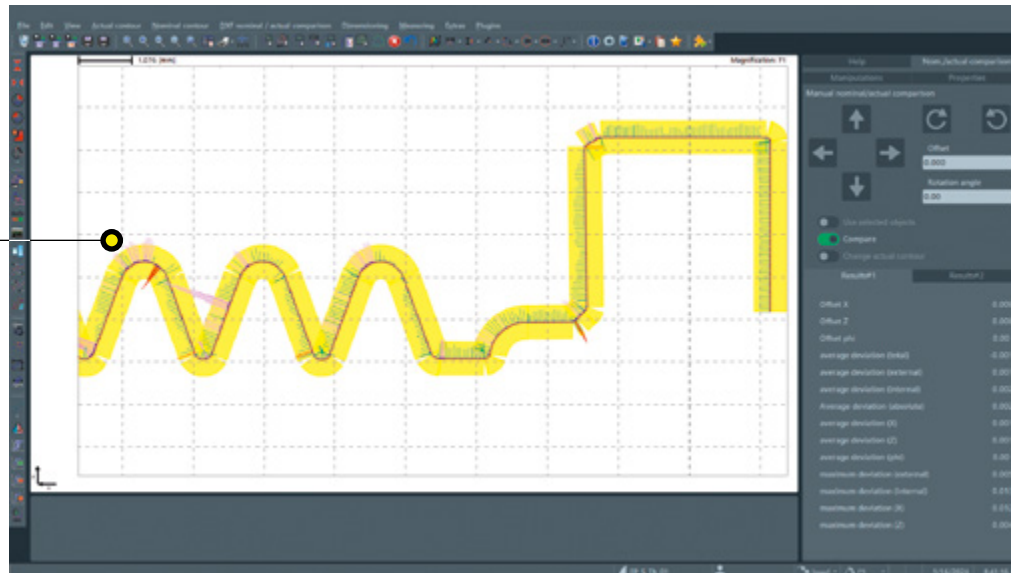

Drawing generator »sinope« – the software automatically generates the tool drawing from the measured actual dimensions of the tool as a supplement to the tabular inspection report. The tool contour is displayed in 2D/3D with a detailed view of the measuring points.



»lasso«-dimension system – for creating complex dimensions of distances and contour elements in just a few steps. It allows flexible, fast and effective dimensioning of actual contours. This is done automatically when a dimensioned nominal contour is provided.

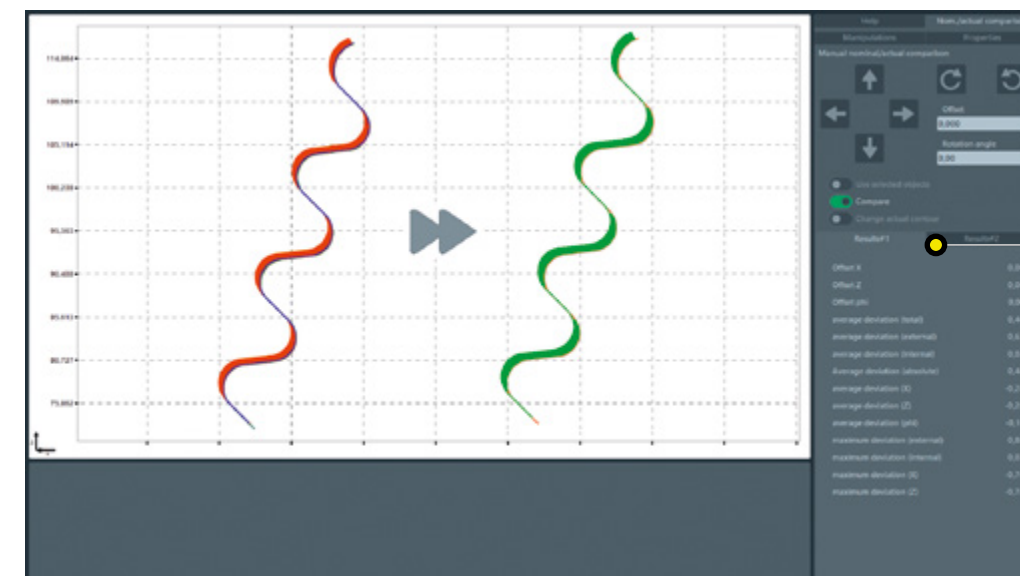
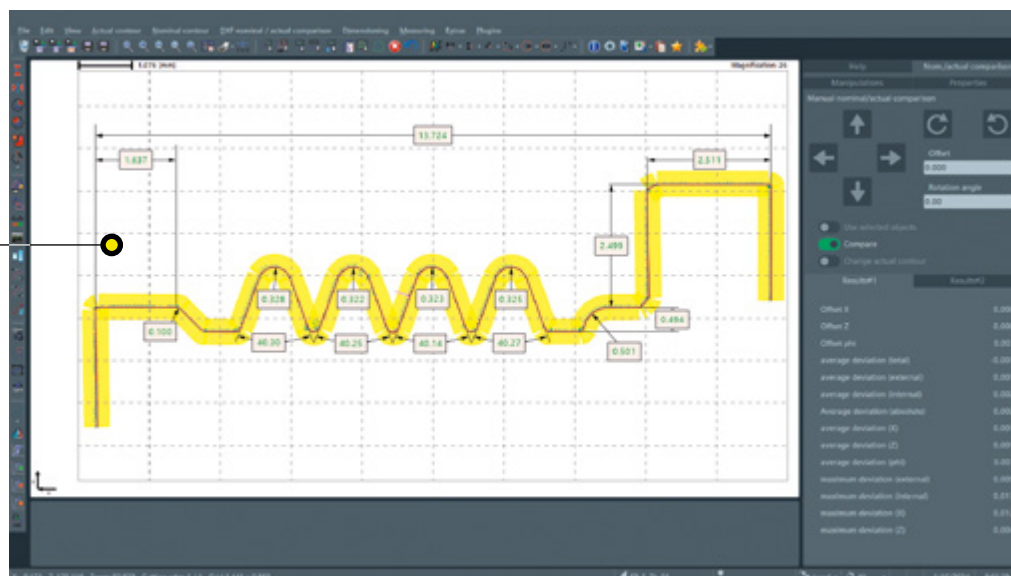

Contour correction »coCon« – after scanning the tool contour, the contour correction of eroded or ground mold tools is automatically calculated using the nominal DXF file. The new contour is output in DXF format.

Perfect Even in Specialties

Precision down the entire line. The »pilot 4.0« software offers innovative solutions for special applications and is continuously developed in-house by ZOLLER, with a large development capacity to meet the requirements of new tool technologies and to implement customer requests, all while also making existing processes even simpler and more efficient. Case in point: the important preparation of grinding wheels for new orders. ZOLLER offers the perfect solution for short set-up and throughput times – from management, storage and assembly to measuring and transferring the measurement data to your grinding machine.



Power Skiving Cutter software – for determining the tool parameters required for use on the machine tool – photo-realistic input dialog and automatic measurement in incident and transmitted light.

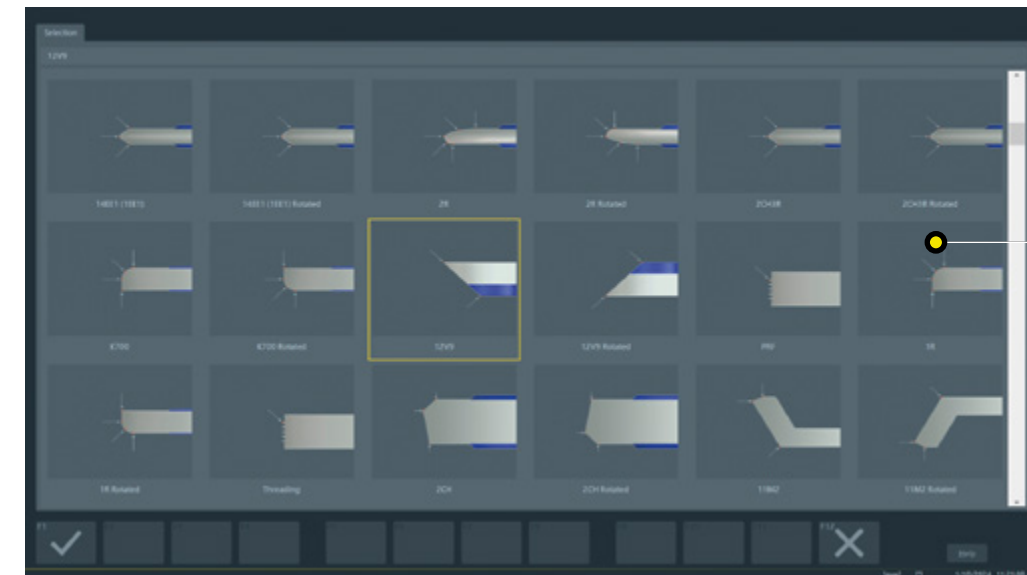
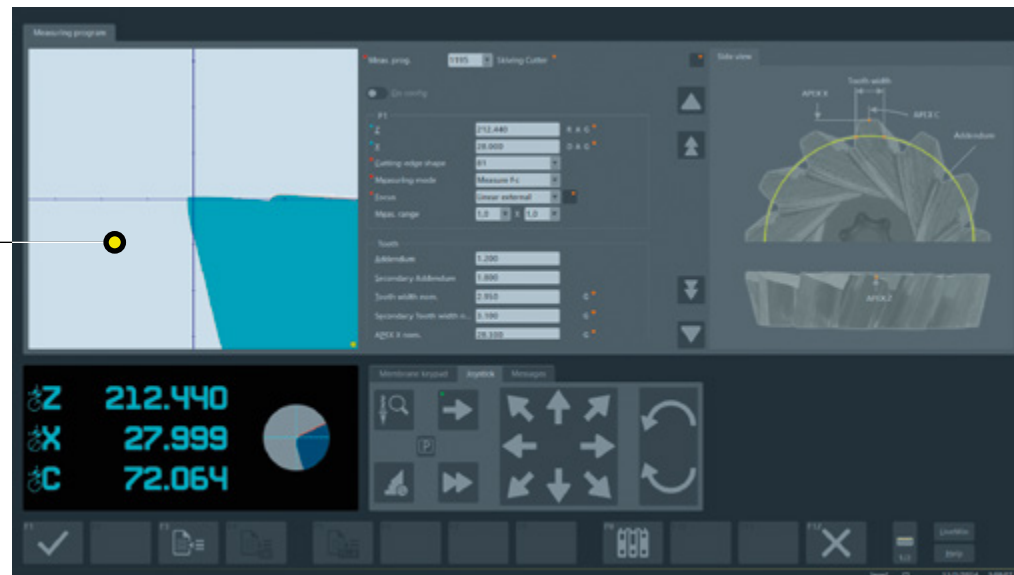

Grinding wheels software – library of grinding wheel types according to FEPA standard as well as grinding machine manufacturer specific types (e.g. ANCA, MAKINO, ROLLOMATIC).



Power Skiving Cutter software – automatic measurement in incident light with the tool inspection camera, including depth image generation for distortion-free measurements and with automatic setting of the illumination intensity for optimal lighting of the surface.

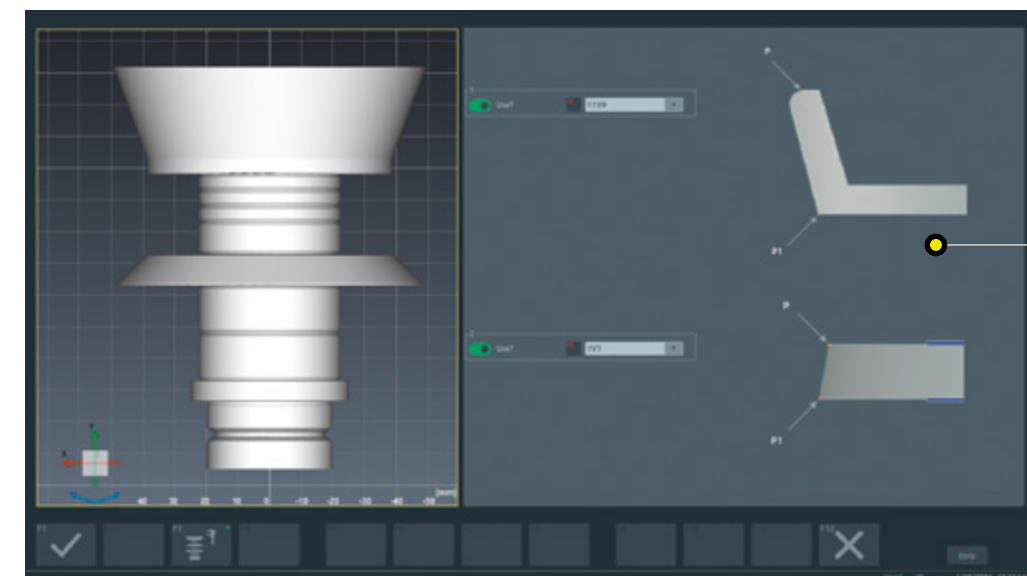
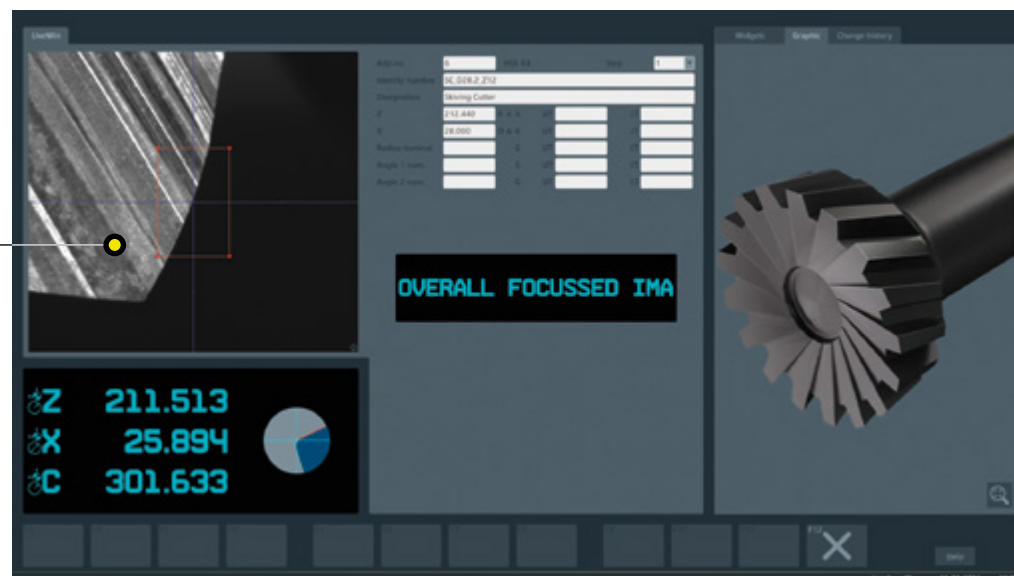

»elephant 2.0« for grinding wheels – scans the contour of the grinding wheel package and determines the individual grinding wheel types fully automatically. The package is then measured and recorded in detail without any data input. The grinding wheel pack can be saved for subsequent measurements.

Logging and Networking Your Data

ZOLLER enables continuous data transfer and secure communication, all thanks to its interlinked systems. Interfaces to your programming systems and grinding machines enable smooth networking and automated data exchange to increase efficiency in your production. Measurement sequences can be prepared and simulated externally using a CAD model of the tool, and measured actual data is transferred to the machine control. For your inspection and measurement results, ZOLLER »pilot 4.0« software offers a wide range of logging options for conclusive proof of tool quality, optimally tailored to your requirements.

Editable inspection report »apus« - to display all measurement results including designations, nominal values, tolerances and much more in tabular form and flexibly in the layout.

Result	Nom. value	U. tol.	L. tol.	Act. value	DIF. value	Stat.
Diameter Step 1	7.300	0.000	-0.050	7.268	-0.032	OK
Radial run-out	0.000	0.010	0.010	0.002	0.002	OK
Axial run-out	0.000	0.010	0.010	0.002	0.002	OK
Step Length 1	4.000	0.000	-0.050	4.000	0.000	OK
Diameter Step 2	10.500	0.000	-0.050	10.498	-0.002	OK
Radial run-out	0.000	0.010	0.010	0.004	0.004	OK
Axial run-out	0.000	0.010	0.010	0.003	0.003	OK
Tap	0.000	0.005	0.005	0.000	0.000	OK
Step Length 2	12.400	0.050	-0.050	12.388	-0.012	OK
Diameter Step 3	11.100	0.000	-0.050	11.096	-0.004	OK
Step Angle	45.000	0.500	-0.500	44.860	-0.140	OK
Radial run-out	0.000	0.010	0.010	0.004	0.004	OK
Axial run-out	0.000	0.010	0.010	0.009	0.009	OK
Step Length 3	22.300	0.050	-0.050	22.295	-0.005	OK
Diameter Step 4	35.000	0.000	-0.050	34.979	-0.021	OK
Step Angle	35.000	0.500	-0.500	34.871	-0.129	OK
Radial run-out	0.000	0.010	0.010	0.003	0.003	OK
Axial run-out	0.000	0.010	0.010	0.003	0.003	OK
Step Length 4	55.000	0.000	-0.050	54.967	-0.033	OK
Diameter Step 5	15.100	0.000	-0.050	15.090	-0.010	OK
Radial run-out	0.000	0.010	0.010	0.151	0.001	OK
Radius	0.000	0.010	-0.010	0.001	0.001	OK
Axial run-out	0.000	0.010	0.010	0.009	0.009	OK
Helix Angle	18.000	1.000	-1.000	18.49	0.49	OK
Helix Angle axial	9.000	0.500	-0.500	8.79	-0.29	OK
Chamber Width axial	0.400	0.050	-0.050	0.420	0.020	OK
Chamber Width axial	0.500	0.000	0.000	0.500	0.000	OK

Example – left – report printout with »apus«.

right – measurement program specific inspection report printout.

Result	Nom. value	U. tol.	L. tol.	Act. value	DIF. value	Tolerance
Diameter Step 1	7.300	0.000	-0.050	7.268	-0.032	OK
Radial run-out	0.000	0.010	0.010	0.002	0.002	OK
Axial run-out	0.000	0.010	0.010	0.002	0.002	OK
Step Length 1	4.000	0.000	-0.050	4.000	0.000	OK
Diameter Step 2	10.500	0.000	-0.050	10.498	-0.002	OK
Radial run-out	0.000	0.010	0.010	0.004	0.004	OK
Axial run-out	0.000	0.010	0.010	0.003	0.003	OK
Tap	0.000	0.005	0.005	0.000	0.000	OK
Step Length 2	12.400	0.050	-0.050	12.388	-0.012	OK
Diameter Step 3	11.100	0.000	-0.050	11.096	-0.004	OK
Step Angle	45.000	0.500	-0.500	44.860	-0.140	OK
Radial run-out	0.000	0.010	0.010	0.004	0.004	OK
Axial run-out	0.000	0.010	0.010	0.009	0.009	OK
Step Length 3	22.300	0.050	-0.050	22.295	-0.005	OK
Diameter Step 4	35.000	0.000	-0.050	34.979	-0.021	OK
Step Angle	35.000	0.500	-0.500	34.871	-0.129	OK
Radial run-out	0.000	0.010	0.010	0.003	0.003	OK
Axial run-out	0.000	0.010	0.010	0.003	0.003	OK
Step Length 4	55.000	0.000	-0.050	54.967	-0.033	OK
Diameter Step 5	15.100	0.000	-0.050	15.090	-0.010	OK
Radial run-out	0.000	0.010	0.010	0.151	0.001	OK
Radius	0.000	0.010	-0.010	0.001	0.001	OK
Axial run-out	0.000	0.010	0.010	0.009	0.009	OK
Helix Angle	18.000	1.000	-1.000	18.49	0.49	OK
Helix Angle axial	9.000	0.500	-0.500	8.79	-0.29	OK
Chamber Width axial	0.400	0.050	-0.050	0.420	0.020	OK
Chamber Width axial	0.500	0.000	0.000	0.500	0.000	OK

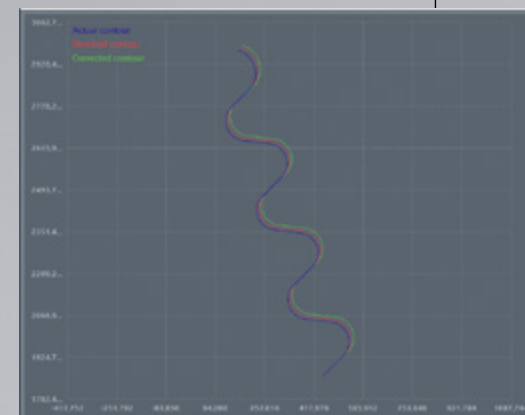
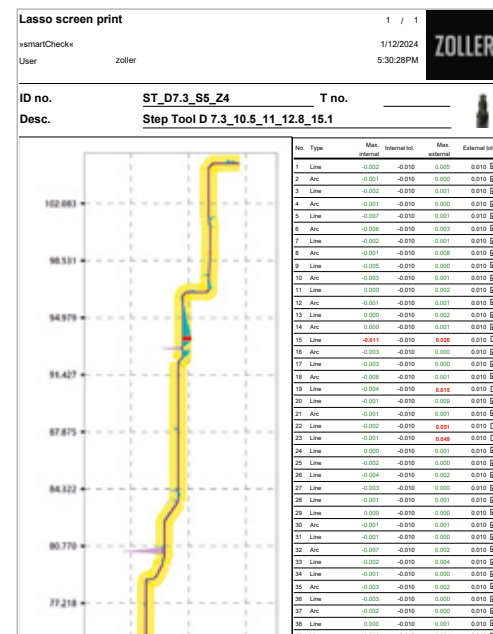

Contour correction for forming tools – nominal/actual comparison of the scanned contour with the nominal contour in DXF format. The software »coCon« inverts the deviations and generates a contour correction, which is transferred to the machine as a new DXF file.



Interfaces – the inspection and measuring device receives a measurement data file from the programming system or the grinding machine and automatically generates the measurement. The measured tool data is transferred from the ZOLLER inspection and measuring device to the programming system or to the machine control, where the NC program is optimized for series production.



Installation Dimensions and Technical Data

Technical data »smileCheck«

Maximum tool length Z	Maximum tool diameter D	Maximum snap gauge diameter d	Travel range Y-axis*	Number of axes	Height H1
420 mm	420/460/620 mm	70 mm	± 50 mm	3-4	~ 1750 mm
600 mm	420/460/620 mm	70 mm	± 50 mm	3-4	~ 1950 mm
800 mm	420/460/620 mm	70 mm	± 50 mm	3-4	~ 2150 mm

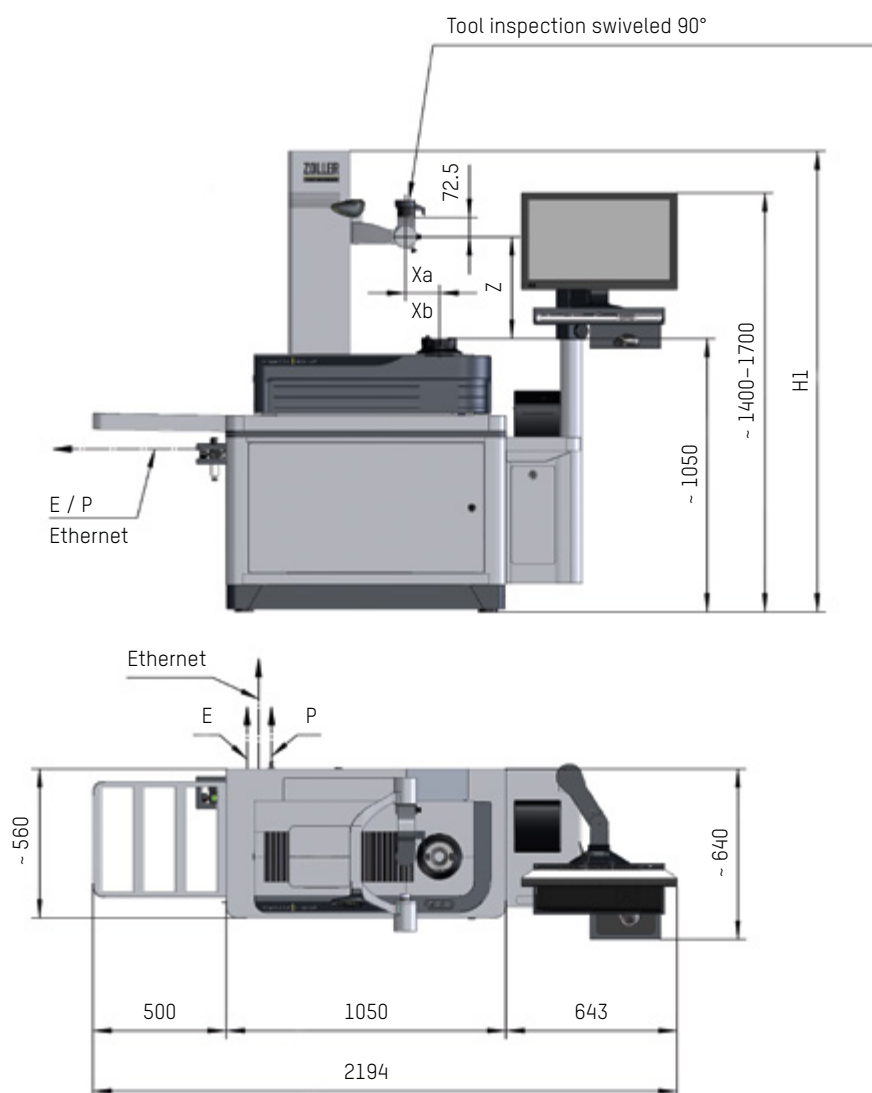

Technical data »smartCheck 450«

Maximum tool length Z	Maximum tool diameter D	Maximum snap gauge diameter d	Travel range Y-axis*	Number of axes	Height H1
450 mm	420/460/620 mm	70 mm	± 50 mm	3-4	~ 1750 mm
620 mm	420/460/620 mm	70 mm	± 50 mm	3-4	~ 1950 mm
820 mm	420/460/620 mm	70 mm	± 50 mm	3-4	~ 2150 mm

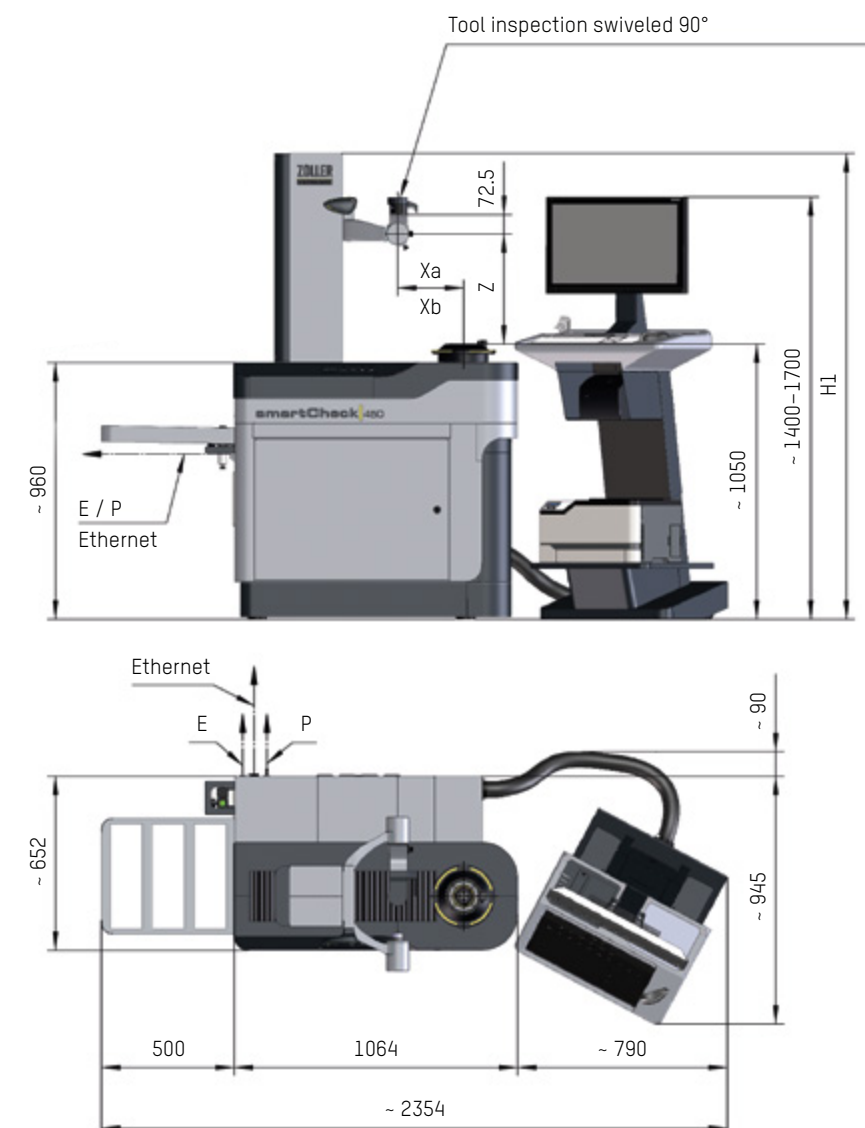

Installation Dimensions and Technical Data

Technical data »smartCheck 600«

Maximum tool length Z	Maximum tool diameter D	Maximum snap gauge diameter d	Travel range Y-axis*	Number of axes	Height H1
600 mm	560/600/660/800 mm	65/85 mm	± 100 mm	3-4	~ 1936 mm
800 mm	560/600/660/800 mm	65/85 mm	± 100 mm	3-4	~ 2136 mm
1000 mm	560/600/660/800 mm	65/85 mm	± 100 mm	3-4	~ 2336 mm
1200 mm	560/600/660/800 mm	65/85 mm	± 100 mm	3-4	~ 2536 mm

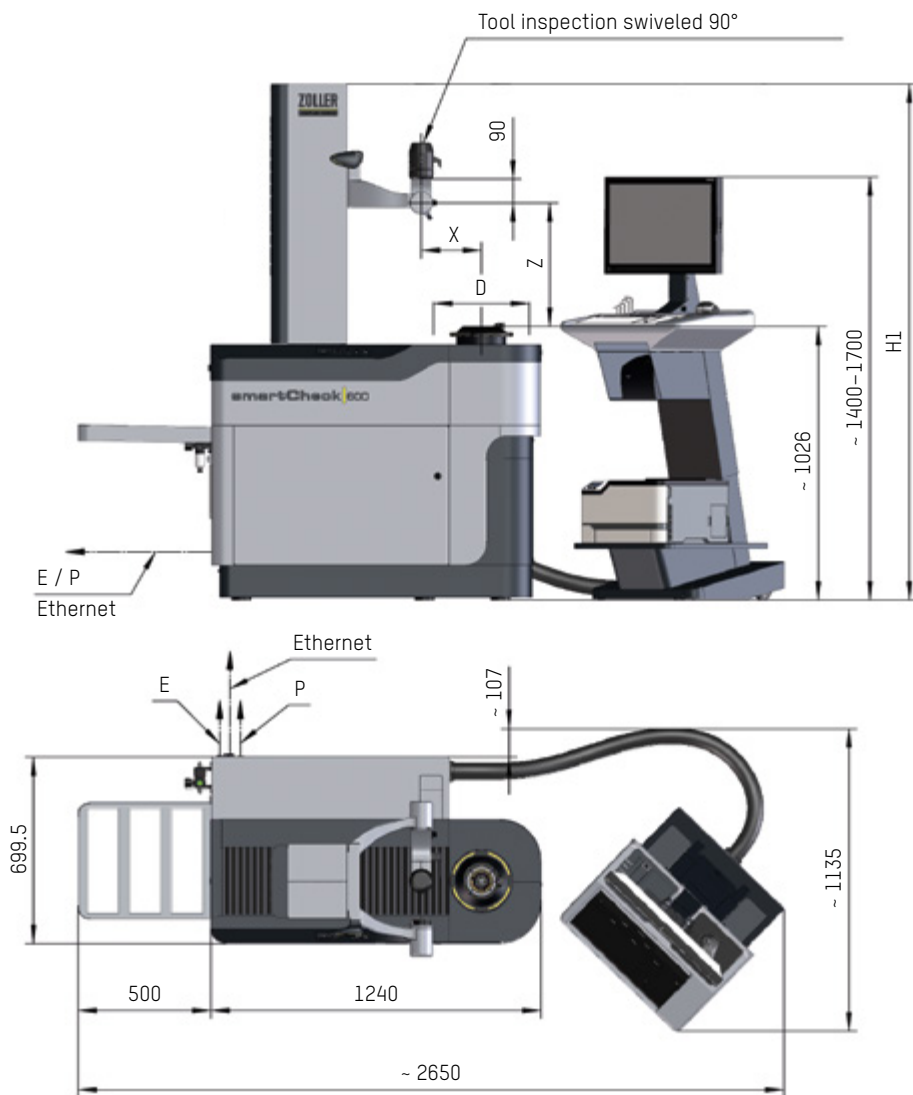

Technical data »smartCheck 800«

Maximum tool length Z	Maximum tool diameter D	Maximum snap gauge diameter d	Number of axes	Height H1
600 mm	860/1000 mm	85 mm	3-4	~ 1936 mm
800 mm	860/1000 mm	85 mm	3-4	~ 2136 mm
1000 mm	860/1000 mm	85 mm	3-4	~ 2336 mm
1200 mm	860/1000 mm	85 mm	3-4	~ 2536 mm

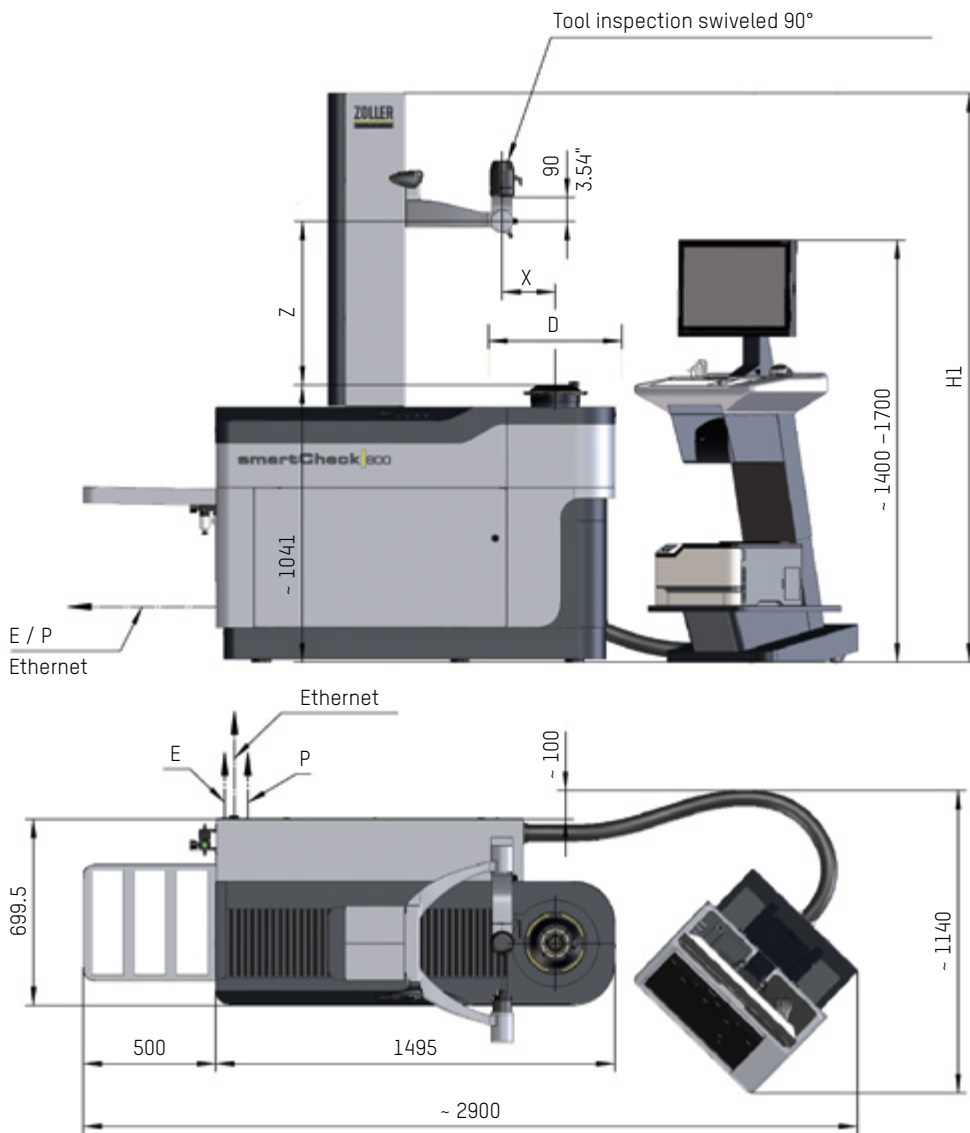

Note: P Air connection, ø 6 E Electrical connection Installation dimensions in mm *optional

Technical Data

Technical data	»smileCheck«	»smartCheck 450«	»smartCheck 600«	»smartCheck 800«
Axes				
One-hand control handle »eQ«	●	●	●	●
CNC drive (Z, X)	●	●	●	●
Fine adjustment/handwheels (Z, X)	⊙	⊙	⊙	⊙
Angle measuring system C-axis	⊙	●	●	●
CNC/autofocus	⊙	●	●	●
CNC/Y-axis	⊙	⊙	⊙	-
CNC/swiveling optics carrier (A) ^[1]	-	-	⊙	⊙
Electronics				
24" TFT color monitor with software »pilot 4.0«	●	●	●	●
Additional 17" satellite monitor	⊙	⊙	⊙ ^[2]	⊙ ^[2]
Integrated control unit with keyboard/mouse	●	⊙	⊙	⊙
Separate control unit »cockpit«	⊙	●	●	●
Spindle				
High-precision spindle SK 50/Vacuum ^[3]	●	⊙	⊙	⊙
High-precision spindle »pcs«	⊙	-	-	-
High-precision spindle »ace« size 1	-	●	●	●
High-precision spindle »ace« size 2	-	-	⊙	⊙
Tailstock				
Pneumatic counter center	-	-	⊙	⊙
Camera/sensors configuration				
Transmitted light camera HR50, BF approx. 7.3 x 6.7 mm ²	●	●	●	●
Transmitted light camera HR50 1:1, BF approx. 4.0 x 3.6 mm ²	-	⊙	⊙	⊙
Transmitted light camera HR70 1:1, BF approx. 4.0 x 3.6 mm ²	⊙	⊙	⊙	⊙
Transmitted light camera 5 Mpx, BF approx. 4.4 x 4.0 mm ²	-	⊙	⊙	-
Transmitted light camera WF, BF approx. 15.5 x 14.1 mm ²	-	-	⊙	-
Incident light camera, BF approx. 7.1 x 6.5 mm ²	●	●	-	-
Incident light camera, BF approx. 4.4 x 4.0 mm ²	-	-	●	●
Cutting edge inspection LED incident light	●	●	●	●
Standard tool inspection	●	●	-	-
Premium tool inspection	-	-	●	●
Stable table				
Integrated	●	●	●	●
Tool identification				
RFID Manual »mslz«	⊙	⊙	⊙	⊙
RFID Manual »msle«	⊙	⊙	-	-
RFID Manual/drive slot	⊙	-	-	-
RFID Semi-automatic/drive slot	⊙	⊙	⊙	⊙
RFID Automatic/drive slot	-	⊙	⊙	⊙
RFID Automatic/head bolt	-	⊙	⊙	⊙
Code scanner Manual/drive slot	⊙	⊙	⊙	⊙
Code scanner Automatic/drive slot	-	⊙	⊙	-

[1] Not possible in combination with Y-axis

[2] Only in combination with »cockpit«

[3] Option

● Base model ⊙ optional - not possible

”

ZOLLER inspection and measuring machines deliver highly professional measurement results and increase the performance of our production.

We are moving into the future with complete conviction.

Stefan Bailom, Technical Manager
CERATIZIT Deutschland GmbH, Kempten

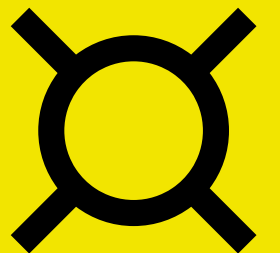

Pioneering Efficiency for your Grinding Shop

The highest potential for greater efficiency lies outside the grinding machine: ZOLLER Solutions stand for your future – we make you more successful. If you can manufacture your parts faster and more efficiently, you can work more economically and invest in the future. If economic progress is your goal, then ZOLLER is your partner.



Made in Germany – Available Wherever You Are

Your Advantage
ZOLLER presence
Global. Close. Personal.

ZOLLER quality is “made in Germany” – and there for you, anywhere in the world.

Our company has its own locations and branches at 85 sites in 62 countries, guaranteeing we are close to customers and can provide first-class, personal customer service in local markets.

- Parent company
- Headquarters
- Branch office
- Representative

GERMANY

HEADQUARTERS

E. ZOLLER GmbH & Co. KG
Einstell- und Messgeräte
Gottlieb-Daimler-Straße 19
D-74385 Pleidelsheim
Tel: +49 7144 8970-0
Fax: +49 7144 8970-70191
post@zoller.info | www.zoller.info

ZOLLER NORTH

E. ZOLLER GmbH & Co. KG
Service- und Vertriebszentrum
D-30179 Hannover

ZOLLER EAST

E. ZOLLER GmbH & Co. KG
Service- und Vertriebszentrum
D-04158 Leipzig

ZOLLER WEST

E. ZOLLER GmbH & Co. KG
Service- und Vertriebszentrum
D-40764 Langenfeld

EUROPE

AUSTRIA

ZOLLER Austria GmbH
A-4910 Ried im Innkreis
office@zoller-a.at | www.zoller-a.at

SWITZERLAND

ZOLLER Schweiz GmbH
CH-9016 St. Gallen
info@zoller-ch.com | www.zoller-ch.com

FRANCE

ZOLLER France
F-67380 Lingolsheim
info@zoller.fr | www.zoller.fr

SPAIN + PORTUGAL

ZOLLER Ibérica S.L.
E-08005 Barcelona
correo@zoller.info | www.zoller.info

SWEDEN

ZOLLER Sweden AB
SE-63221 Eskilstuna
info@zoller-se.com | www.zoller.info

TURKEY

ZOLLER Ölçüm Teknolojileri San.ve Tic. Ltd. Sti.
TR-16120 Nilüfer / Bursa
info@zoller-tr.com | www.zoller-tr.com

RUSSIA

LLC ZOLLER Russia
RU-111123 Moscow, Russia
info@zoller-ru.com | www.zoller-ru.com

ISRAEL

ZOLLER Israel GmbH
Ramat Yishay 3009500
info@zoller-il.com | www.zoller.info

POLAND

ZOLLER Polska Sp. z o.o.
63-100 Śrem
biuro@zoller-a.at | www.zoller.net.pl

CZECH REPUBLIC + SLOVAKIA

ZOLLER Czech s.r.o.
602 02 Brno
info@zoller.cz | www.zoller.cz

AMERICA

USA

ZOLLER Inc.
North American Headquarters
USA-48108 Ann Arbor, MI
sales@zoller-usa.com | www.zoller.info/us

ZOLLER Inc. Pacific

USA-90503 Torrance, CA
sales@zoller-usa.com | www.zoller.info/us

CANADA

ZOLLER Canada Inc.
CAN-LSN 864 Mississauga, ON
sales@zoller-canada.com | www.zoller.info/ca

MEXICO

ZOLLER Tecnologías S de R.L. de C.V.
MEX-C.P. 76030 San Angel Querétaro
sales@zoller-mexico.com | www.zoller.info/mx

BRAZIL

ZOLLER do Brasil
BRA-CEP 13284-198 Nova Vinhedo,
Vinhedo - São Paulo
comercial@zoller-br.com | www.zoller-br.com

ASIA

INDIA

ZOLLER India Private Ltd.
IN-Pune 411019 Maharashtra, India
info@zoller-in.com | www.zoller-in.com

CHINA

ZOLLER Shanghai, Ltd.
Asia Pacific Regional Headquarter
RC-201108 Shanghai
info@zoller-cn.com | www.zoller-cn.com

ZOLLER Asia Pacific, Ltd.

RC-Kowloon, Hongkong
info@zoller-cn.com | www.zoller-cn.com

JAPAN

ZOLLER Japan K. K.
JP-564-0037 Osaka, Japan
info@zoller-jp.com | www.zoller-jp.com

THAILAND

ZOLLER (Thailand) Co. Ltd.
Amphur Muang Chonburi, TH-20000 Thailand
info@zoller-in.com | www.zoller-th.com

INDONESIA

ZOLLER Singapore Pte. Ltd
Indonesia Representative Office
Tambun-17510, Bekasi, Jawa Barat
info@zoller-in.com | www.zoller-in.com

SINGAPORE

ZOLLER Singapore Pte. Ltd
SG-199589 Singapore
info@zoller-in.com | www.zoller.info

MALAYSIA

ZOLLER MALAYSIA SDN. BHD.
Malaysia Representative Office
MY-Petaling Jaya | Selangor Darul Ehsan, Malaysia
lau@zoller-my.com | www.zoller-in.com

VIETNAM

ZOLLER Vietnam
VNM-Ho Chi Minh City, Vietnam
info@zoller-in.com | www.zoller-in.com

KOREA

ZOLLER Korea Co., Ltd.
KOR-15119 - Siheung-Si, Gyeonggi-Do, Südkorea
info@zoller-kr.com | www.zoller-kr.com

REPRESENTATIVES

Argentina, Australia, Belgium, Bolivia, Chile, Colombia, Costa Rica, Croatia, Denmark, Estonia, Finland, Great Britain, Hungary, Iran, Ireland, Italy, Lettland, Latvia, Luxembourg, New Zealand, The Netherlands, Norway, Pakistan, Peru, Romania, Saudi Arabia, South Africa, Southern Tyrol, Taiwan, United Arab Emirates, Venezuela.



Your Customer Portal
www.myzoller.com

simple. direct. online.

ZOLLER Solutions

More speed, higher quality, safe processes – with ZOLLER, you increase the efficiency of your production. ZOLLER offers you outstandingly precise devices for adjusting, measuring and testing cutting tools, software, interfaces, cloud services and solutions for the automation of tool processes. You can combine all of this to create your individual system solution – on your way to the smart factory.

Presetting & Measuring

Tool Management

Inspection & Measuring

Automation

Everything from a Single Source.
Everything for your Success.
Everything with ZOLLER Solutions.

ZOLLER
expect great measures

Headquarters in Pleidelsheim
E. ZOLLER GmbH & Co. KG
Tool presetter and measuring machines
Gottlieb-Daimler-Straße 19 | D-74385 Pleidelsheim
Phone: +49 7144 8970-0 | Fax: +49 7144 8970-70191
post@zoller.info | www.zoller.info